

THE IMPACT OF COERCIVE POWER AND IMPOSITION OF SANCTIONS IN SANTRI STUDENT ACADEMIC LEARNING

Erik Saut Hatoguan Hutahaean, Yuarini Wahyu Pertiwi, Djuni Thamrin

Universitas Bhayangkara Jakarta Raya

Corresponding Email: erik.saut@dsn.ubharajaya.ac.id

ABSTRACT

The phenomenon of santri students (Islamic Boarding School Students) in Indonesia encompasses various aspects that reflect the influence of pesantren (Islamic Boarding School) education and Islamic values on their experiences and identities in the university environment. Santri students in Indonesia, like students in general, may also encounter various challenges during their university studies. However, there are some issues that are more commonly experienced by santri students, particularly related to their educational backgrounds in pesantren and their religious experiences. A total of 186 santri students were involved in filling out questionnaires measuring academic commitment, the application of coercive power, the imposition of sanctions, and compliance. Based on mediation analysis, the results indicated that the application of coercive power and the imposition of sanctions can serve as appropriate mediators in bridging the influence of academic commitment to compliance. Compliance among santri students is not solely a result of their academic commitment because the level of compliance can be shaped by the university's application of coercive power and the imposition of sanctions for students who violated rules.

Keywords: Students, Santri, Learning

Submission	Review Process	Revised	Accepted	Published
09-09-2023	18-09-2023 - 23-11-2023	04-12-2023	04-12-2023	18-12-2023

INTRODUCTION

Santri students are individuals who have completed their basic education in Islamic boarding schools (pesantren) and then continue their formal education at colleges or universities, while maintaining their involvement and commitment to the religious and spiritual activities they learned while being santri at pesantren (Suhermanto et al., 2017). The combination of formal education at the university and the deepening of religious values from pesantren can provide santri students with a unique and rich perspective that integrates academic aspects with spiritual and Islamic dimensions (Bali, 2017).

Learning among santri students can encompass several unique and intriguing aspects because they bring deep religious educational experiences from Islamic boarding

schools (pesantren) into the university environment (Abdi et al., 2021). Santri students tend to have a more holistic view of life (Rofiq & Siddik, 2019) as they are accustomed to integrating spiritual aspects with academics. They may be better equipped to contemplate the profound meanings of their studies and understand their ethical implications. Some santri students may face identity conflicts between the more secular academic world and their religious values (Kosasih et al., 2023). The experiences of santri students can vary greatly depending on their personal backgrounds, the type of university they attend, and their interactions with their surroundings. While their educational experiences in pesantren provide a strong foundation, new challenges and opportunities also arise when they are in university.

Compliance is one of the aspects that may pose challenges for santri students when pursuing their studies at the university (Ulum, 2017). Although santri students are generally accustomed to the strict structure and routines in the pesantren environment, they may face compliance challenges when in a more liberal university setting. In universities, class schedules are often more flexible, and teaching methods can vary (Mustaghfiroh, 2020). Santri students, who are used to a strict schedule in pesantren, may find it challenging to adapt to a more relaxed schedule at the university.

In university, most learning is more independent (Safrida, 2021). Santri students need to learn how to seek information, conduct research, and prepare course materials more independently. Universities often have different concepts compared to pesantren (Kadir, 2020), with many temptations and distractions that may not exist in pesantren. This can affect concentration and study focus. Santri students can develop time management skills, plan their daily schedules, utilize university support facilities (such as academic guidance centres), and seek support from fellow students, professors, or the university itself.

Compliance among santri students, although generally considered a positive asset, can also become a matter of concern in some situations. Excessive compliance from the pesantren environment can sometimes lead to a lack of flexibility or difficulties in adapting to the more liberal university environment. Compliance based on strict supervision and regulations in pesantren can make santri students more dependent on external oversight (Yanti, 2022). Life in pesantren involves rigorous external supervision to prevent violations (Perawironegoro, 2019). When santri students undergo a transition to a more independent university environment, they may

struggle to self-manage without direct supervision.

Research related to compliance and academic commitment in students, including santri students, has been extensively conducted. Some studies have addressed compliance with rules (Subekti & Laksmiwati, 2019), examining how compliance relates to time management (Penita 2022), attending classes, and completing academic tasks (Oktia, 2022), which can impact their level of academic commitment. Earlier research has successfully explored how a lecturer's power style predicts compliance and academic commitment (Pertiwi & Perdini, 2022).

Coercive power is one of the types of authority that involves threats or the imposition of sanctions to compel others to perform specific actions (Biddle, 2020). In the context of education, including santri students, coercive power can be related to the imposition of sanctions as a form of discipline (Y. Huang & Xu, 2020). Academic commitment refers to the level of expectations regarding educational development and goals (Griep, 2023). Academic commitment is essential because it encompasses belief in academic values, a desire to achieve high standards, and motivation to actively engage in the learning process. Compliance, on the other hand, needs to be shaped to depict the extent to which students maintain routines, adhere to rules, and fulfill their academic responsibilities. Coercive power involves the use of threats or sanctions as a means to control someone's behavior. In this context, coercive power refers to educational institutions' (such as universities or pesantren) efforts to regulate student behavior through threats or the imposition of sanctions if compliance is not adhered to.

RESEARCH METHODS

The research was conducted on 186 students who are santri in the city of Jepara.

Respondents were selected based on the characteristics of male and female santri from pesantren who were pursuing their education at the university. The respondents were provided with instruments to measure academic commitment, perceptions of the application of coercive power by the university, assessments of the existence of sanctions, and a compliance scale. The measurement scales were validated through pilot testing among santri students. Validity was tested through content validity, involving input from seven experts representing scholars and educational practitioners.

Data analysis for the research utilized structured analysis techniques, involving the application of coercive power and the presence of sanctions as variables mediating the relationship between academic commitment and compliance.

RESULTS AND DISCUSSION

Relevant data such as statistics, figures, and variable measurements were used to provide an overview of the observed situation in the research. Descriptive analysis provides guidance for identifying general trends and offers an initial understanding of how conceptualized variables are applied in the academic environment. Data on academic commitment, the application of coercive power and sanctions, and compliance were analyzed objectively without delving into in-depth interpretations. Data representation was based on an understanding of academic commitment, the application of coercive power, the imposition of sanctions, and compliance, as well as how gender factors could have an influence on them.

Table 1: Statistical Description of Academic Commitment, Coercive Power, Sanctions, and Obedience

	Academic Commitment		Coercive Power		Sanctions		Obedience	
	Male	Female	Male	Female	Male	Female	Male	Female
Valid	97	85	97	85	97	85	97	85
Missing	0	0	0	0	0	0	0	0
Mean	96.124	82.118	70.804	66.376	71.082	68.965	72.134	69.906
Std. Deviation	12.932	16.571	8.107	9.313	7.727	10.555	7.963	9.079
Minimum	70.000	31.000	43.000	40.000	47.000	38.000	53.000	37.000
Maximum	119.000	110.000	82.000	86.000	89.000	90.000	90.000	90.000

The calculation results showed that male santri students have a higher average score, and this trend is consistent across all research variables. Academic commitment among male santri students was higher compared to female santri students. This suggested that gender can be a factor influencing the level of academic commitment among santri students. However, this trend was not observed in compliance, as both male and female students exhibited similar average values. Gender did not seem to be a basis for concluding the level of compliance among santri students.

Coercive power, on the other hand, appeared to be somewhat influenced by gender characteristics. The perception that the academic environment imposed coercion is more pronounced among male santri students. This was not the case with the imposition of sanctions. Gender did not seem to be a characteristic that influences the perception of the academic environment implementing sanctions for rule violations.

Table 2: Independent Samples T-Test Analysis Based on Gender

	t	df	p
Academic Commitment	6.394	180	< .001
Coercive Power	3.429	180	< .001
Obedience	1.764	180	0.079
Sanctions	1.557	180	0.121 ^a

Note. Student's t-test.

^a Levene's test is significant ($p < .05$), suggesting a violation of the equal variance assumption

The level of academic commitment among male santri students was significantly different. The academic commitment of female santri students was lower compared to male santri students. The perception of the application of coercive power from the environment was not strongly felt by female santri students, but coercive power emanating from the campus environment was more pronounced among male santri students. On the other hand, the effect of the imposition of sanctions between male and female santri students was similar, with no significant differences observed. The same applied to compliance, as both male and female santri students exhibit similar levels of compliance.

Pearson's Correlations

Variable		Academic Commitment		Coercive Power		Obedience		Sanctions
1. Academic Commitment	Pearson's r	—						
	p-value	—						
2. Coercive Power	Pearson's r	0.543	***	—				
	p-value	< .001		—				
3. Obedience	Pearson's r	0.551	***	0.559	***	—		
	p-value	< .001		< .001		—		
4. Sanctions	Pearson's r	0.477	***	0.685	***	0.549	***	—
	p-value	< .001		< .001		< .001		—

* $p < .05$, ** $p < .01$, *** $p < .001$

All the descriptive findings so far had not depicted the interactions that occur among academic commitment, the application of coercive power, the imposition of sanctions, and compliance in santri students. Interaction analysis was necessary to examine the relationships between research variables and the patterns within these variable relationships. The analysis has found significant correlations among academic commitment, the application of coercive power, the imposition of sanctions, and compliance. They all exhibited consistent interaction patterns, for example, high academic commitment is followed by high perceptions of the application of coercive power and the imposition of sanctions, as well as high compliance. These results indicated that the discipline observed in santri students is determined by the strength of the relationships with academic commitment, the application of coercive power from the environment, and the imposition of sanctions.

Table 3: Analysis of the Influence of Academic Commitment on Compliance Involving Mediators of Coercive Power and Imposition of Sanctions

				Estimate	Std. Error	z-value	p	95% Confidence Interval	
								Lower	Upper
Academic Commitment	→	Obedience	(Total direct)	0.165	0.037	4.412	< .001	0.092	0.238
Academic Commitment	→	Coercive Power	→ Obedience	0.062	0.026	2.346	0.019	0.010	0.114
Academic Commitment	→	Sanctions	→ Obedience	0.063	0.023	2.686	0.007	0.017	0.108
Academic Commitment	→	Obedience	(Total indirect)	0.125	0.024	5.140	< .001	0.077	0.172
Academic Commitment	→	Obedience	(Total effect)	0.289	0.032	9.003	< .001	0.226	0.352

Note. Robust standard errors, robust confidence intervals, ML estimator.

The overall impact of the academic commitment variable on the compliance variable encompasses all aspects or dimensions that may exist within both variables. There was a positive relationship between the level of academic commitment and the level of compliance. This means that the higher someone's level of academic commitment, the more likely they are to adhere to rules, discipline, and academic tasks. The impact or influence of academic commitment on compliance was considered statistically significant or substantial. This implied that the academic commitment variable provides a relatively strong contribution in explaining the variation in the compliance variable.

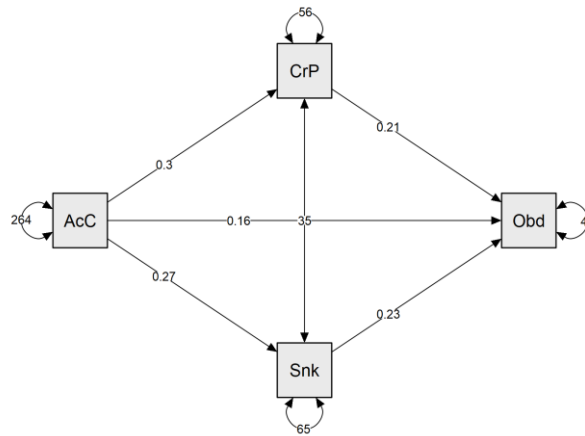

Figure 1: Diagram of the Analysis of the Application of Coercive Power and Imposition of Sanctions as Mediators

The analysis results have found that academic commitment has a significant direct impact on compliance (direct total effect). In this context, the "direct total effect" referred to the influence of academic commitment on compliance without passing through other mediating factors or control variables. This can be interpreted as individuals with high levels of academic commitment tend to be more obedient to tasks, rules, or norms related to the academic environment. Increased academic commitment can enhance motivation to adhere to tasks and rules, which, in turn, can lead to better compliance.

The mediation analysis results have shown that the application of coercive power and the imposition of sanctions played a role in explaining how academic commitment influences compliance. This means that the effect of academic commitment on compliance was explained by the mediating role of coercive power and sanctions. Factors such as the implementation of coercive power

and the imposition of sanctions on students who violated rules can act as mediators between the influence of academic commitment on compliance. The impact of academic commitment on the compliance of santri students can be explained through the strength of coercive power applied by the campus and the policies of imposing sanctions on students who violated rules. This implied that compliance starts from an internal factor, namely academic commitment, and external factors (coercive power and sanctions from the environment).

DISCUSSION

In principle, each individual is unique and possesses different experiences and motivations related to education (Y. Huang et al., 2018). Differences in the level of academic commitment between males and females in a specific population can occur. These differences may be attributed to factors such as commitment to developing an academic career, where women may initially underestimate their commitment when building an academic career (Faniko et al., 2021). Additionally, socio-economic factors can influence educational opportunities and individual development.

However, it's also possible that factors influencing academic commitment in individuals apply similarly to both male and female students (Quadlin, 2018). Power cannot be separated from the concepts of gender and language. The relationship between the two is always influenced by cultural factors (Jalil & Aminah, 2018). Differences in how male and female students assess "coercive" power or coercion can be influenced by several factors, including culture, personal experiences, social norms, and individual perceptions. Culture and social communication can influence one's views on power and how they evaluate "coercive" situations. Some cultures may be more supportive of or emphasize strong masculinity (Wood & Fixmer-Oraiz, 2018), which can affect how men and women perceive dominant power or coercion. This can be observed in the culture within pesantren life. Men and women may have different views on how power should be used and its impact on individuals and groups. These perceptions can be influenced by social experiences and personal values. Gender expectations that have been established in society can influence how someone interprets power and coercion. The traditional roles expected of men and women in various situations can affect their views on power-related actions. This is a result of gender imbalances (Iqbal & Harianto, 2022).

The compliance of male and female students with specific rules or norms can be influenced by various factors, including socio-cultural, psychological, and environmental factors. In many cultures, there are social norms that guide individual behavior and actions. Most of these

norms apply regardless of gender. Students, both male and female, generally grow up in a pesantren culture that teaches the importance of adhering to applicable norms (Bali, 2019). The environment in which students are situated, such as the pesantren, campus, or family environment, can also influence their compliance with specific norms. If the environment encourages compliance with certain norms based on equality (Mawardi J, 2018), both men and women are likely to respond in similar ways.

In general, it is not always true that male and female santri students tend to have the same perceptions of sanctions for indiscipline. Some studies indicate that gender stereotypes can influence people's perceptions of specific behaviors (Ellemers, 2018). If there is a perception that male or female santri students tend to be more or less obedient than the other, this can affect how they assess sanctions for indiscipline. However, if there is similarity in these assessments, some psychological and social factors may play a role in shaping perceptions and attitudes toward sanctions. Male and female santri students are typically exposed to the same social norms regarding behavior and compliance. If these norms are consistently applied among students of various genders, then they may have similar views regarding sanctions for non-compliance (Ulum, 2017).

Academic commitment can exert a strong influence on students' compliance (Mawarti et al., 2021) because it creates internal drive to be responsible and motivated to adhere to academic tasks (Affuso et al., 2023), follow rules, and behave in accordance with the norms in the academic environment. Students with strong academic commitment feel a sense of responsibility for their education and future. They recognize the importance of learning and academic self-development, making them more likely to abide by rules and norms that support their goals. Students who identify themselves as serious learners or students are more inclined to adhere to existing academic norms (Wahyuni, 2023). Students want to maintain a positive image as individuals committed to education. Academic commitment can also be reinforced by social support from

classmates, professors, and the academic community as a whole. Students who perceive this support are more likely to comply with academic norms because they feel supported and recognized by the academic community.

Academic commitment among students refers to their level of engagement, determination, and dedication to achieving their academic goals (Anokye & Nkwantabisa, 2022). This commitment can be influenced by various factors, including personal motivation, the learning environment, and interactions with professors and peers. One way in which academic commitment can impact students' compliance is through the application of coercive power and sanctions. Coercive power refers to the ability of authorities to enforce specific rules (Trimbur, 2022), regulations, or policies and impose sanctions if those rules are violated. In the educational context, universities or educational institutions have the authority to establish academic requirements and behavioral norms. If students have a high level of academic commitment, they are more likely to respect these rules and policies (Sagala, 2022). This is because santri students want to achieve their academic goals successfully. Sanctions are a form of negative consequences (Peksen, 2019) imposed when students violate established rules or norms. These sanctions can take the form of warnings, academic penalties, suspensions, or even termination of student status. Santri students with strong academic commitment may be more inclined to avoid such violations (Luthfiyah, 2015) because they want to maintain their academic reputation and achieve good results. Santri students may view rule violations as a threat to their academic goals.

CONCLUSION

Gender can indeed influence the level of academic commitment and the perception of coercive power imposed by the campus and pesantren. However, gender cannot differentiate perceptions of sanctions and also cannot determine the formation of compliant attitudes. Punishment is viewed by santri students as something to be avoided to achieve the implementation of rules. For santri students, academic commitment is an essential factor in realizing academic goals, and for whatever reason, every student will comply with and adhere to all academic regulations in place. The environment can play a role by applying coercive power and implementing sanctions. Coercive power and sanctions applied by the campus can mediate the formation of compliance resulting from the strength of academic

commitment among santri students. The campus's efforts to enforce compliance among santri students with the use of coercive power can lead to obedience. The imposition of sanctions against violators of regulations can direct student behavior to comply with all campus rules.

REFERENCES

- Abdi, Y. H., Rizkiana, A., & Panuju. (2021). Pengalaman spiritual Mahasantri pondok pesantren mahasiswa ponorogo. *Jurnal Ilmiah Mahasiswa Universitas Muhammadiyah Ponorogo*, 5(1), 33–51.
- Affuso, G., Esposito, A., Pannone, M., Miranda, M., De Angelis, G., & Bacchini, D. (2023). The effects of teacher support, parental monitoring, motivation and self-efficacy on academic performance over time. *European Journal of Psychology of Education*, 38(1), 1–23.
- Anokye, E., & Nkwantabisa, A. (2022). The influence of academic engagement on academic performance of university accounting students in Ghana. *South African Journal of Accounting Research*, 36(2), 105–122.
- Bali, M. M. E. (2017). Perguruan tinggi Islam berbasis pondok pesantren. *Jurnal Manajemen Pendidikan Islam*, 1(2), 1–14.
- Bali, M. M. E. (2019). Transinternalisasi nilai-nilai kepesantrenan melalui konstruksi budaya religius di sekolah. *Jurnal Pendidikan Agama Islam*, XVI(1), 1–16.
- Biddle, T. D. (2020). Coercion theory: a basic introduction for practitioners. *Texas National Security Review*, 3(2), 99.
- Ellemers, N. (2018). Gender Stereotypes. *Annual Review Psychology*, 69, 275–300.
- Faniko, K., Ellemers, N., & Derks, B. (2021). The Queen Bee phenomenon in Academia 15 years after: Does it still exist, and if so, why? *British Journal of Psychology*, 60, 383–399. <https://doi.org/10.1111/bjso.12408>
- Griep, Y. (2023). Capturing the process of academic commitment: a taxonomy and test of post-secondary student academic commitment trajectories. *Higher Education Research & Development*, 41(6), 1900–1915. <https://doi.org/10.1080/07294360.2021.1967886>
- Huang, Y., & Xu, J. (2020). Surviving the performance management of academic work: evidence from young Chinese academics. *Higher Education Research & Development*, 39(4), 704–718.

- Huang, Y., Backman, S. J., & Backman, K. F. (2018). An investigation of motivation and experience in virtual learning environments : a self-determination theory. In *Education and Information Technologies* (Issue August).
- Iqbal, M. F., & Harianto, S. (2022). Prasangka , Ketidaksetaraan , dan Diskriminasi Gender dalam Kehidupan Mahasiswa Kota Surabaya : Tinjauan Pemikiran Konflik Karl Marx. *Jurnal Ilmiah Ilmu Sosial*, 8(2), 187–199.
- Jalil, A., & Aminah, S. (2018). Gender Dalam Perspektif Budaya dan Bahasa. *Jurnal Al-Maiyyah*, 11(2), 278–300.
- Kadir, A. (2020). Pesantren; prespektif sejarah, kontribusi dan model pendidikan. *Jurnal Da'wah*, 3(1), 69–105.
- Kosasih, O., Islam, U., & Bandung, N. (2023). Pendidikan tinggi Agama Islam dan kohesi sosial di Indonesia. *TSAQOFAH Jurnal Penelitian Guru Indonesia*, 3(2), 283–299.
- Luthfiyah, S. Q. (2015). Faktor-faktor yang berpengaruh terhadap pencegahan pelanggaran akademik mahasiswa akuntansi uin syarif hidayatullah jakarta. Universitas Islam Negeri Syarif Hidayatullah.
- Mawardi J, M. (2018). Gender dan hak asasi perempuan. *Jurnal KomuniKa UIN Raden Intan*, 234–247.
- Mawarti, R. ., Hakim, S. ., Habibi, M. ., Pramesti, L. ., Shofa, A. M. ., & Alfaqi, M. . (2021). Perilaku menyimpang mahasiswa dalam kinerja akademik student deviant behavior in academic performance at universities. *Jurnal Ilmiah Pendidikan Pancasila Dan Kewarganegaraan*, 6(1), 210–219.
- Mustaghfiroh, S. (2020). Konsep “ Merdeka Belajar ” Perspektif Aliran Progresivisme. *Jurnal Studi Guru Dan Pembelajaran*, 3(1), 141–147.
- Oktia, V. (2022). Pengaruh Academic Burnout dan Academic Engagament Terhadap School Well-Being Santri Pesantren. *Nusantara Journal of Behavioral and Social Science*, 1(3), 89–94.
- Peksen, D. (2019). When do imposed economic sanctions work? A critical review of the sanctions effectiveness literature. *Deence and Peace Economics*, 30(6), 2019.
- Perawironegoro, D. (2019). Manajemen Asrama di Pesantren. *TADBIR Jurnal Studi Manajemen Pendidikan*, 3(2), 129–144.
- Pertiwi, Y. W., & Perdini, T. A. (2022). Analysis of Lecturer’ s power styles and student ’ s commitment to predict student ’ s obedience in learning activities. *Education, Sustainability & Society (ESS)*, 5(2), 56–60. <https://doi.org/10.26480/ess.0>
- Quadlin, N. (2018). The Mark of a Woman ’ s Record : Gender and Academic Performance in Hiring. *American Sociological Review*, 83(2), 331–360. <https://doi.org/10.1177/0003122418762291>
- Rofiq, A., & Siddik, M. F. . (2019). Pembinaan karakter dalam pendidikan Islam holistik berbasis pesantren. *Ilmuna*, 1(2), 82–100.
- Safrida, N. (2021). Implementasi Kampus Merdeka : Implikasi pada Mahasiswa Perguruan Tinggi Negeri di Aceh Barat. *Indonesian Journal of Teaching and Teacher Education*, 1(1), 19–28.
- Sagala, S. (2022). Etika Akademik di Perguruan Tinggi. *Jurnal Pendidikan Dan Konseling*, 4(6), 8359–8370.
- Subekti, A. F., & Laksmiwati, H. (2019). Hubungan Antara Religiusitas Dengan Kepatuhan Santri Dalam Mentaati Aturan di Pondok Pesantren. *Character: Jurnal Penelitian Psikologi*, 6(1), 1–4.
- Suhermanto, Wahid, A., & Saleh, B. (2017). Ambivalensi perilaku mahasiswa santri dalam era globalisasi. *Jurnal Pedagogik*, 04(01), 203–210.
- Trimbur, L. (2022). Coerced : Work under Threat of Punishment. *Contemporary Sociology: A Journal of Reviews*, 51(5), 2022.
- Ulum, R. (2017). Hubungan kematangan emosi dengan kepatuhan mahasiswa baru Mabna Faza di Ma"hd putri UIN Malang. Universitas Islam Negeri Maulana Malik Ibrahim.
- Wahyuni, E. . (2023). Kesejahteraan Subyektif Mahasiswa. Deepublish.
- Wood, J. ., & Fixmer-Oraiz, N. (2018). Gendered lives. Cengage Learning.
- Yanti, F. (2022). Komunikasi Pesantren. In Agree Media Publishing.